

PIC Res Comm 2008 March; 3/1
Original published in Med Chem 2009, 5 (1), 23-28

Arterial Vascular Effects of Non-steroidal Antiphlogistic Drugs - A Biochemical Model on an Intramural Induction of Arteriosclerosis

Rainer K. Liedtke. MD
PIC, Munich, Germany, liedtke@pharmed.de

Key words. Arteriosclerosis * NSAID * metastatic calcification * hypertension * chronic kidney disease * dialysis

Abstract. The causes of increased rates of myocardial infarctions and apoplexies by application of non-steroidal anti-inflammatory agents (NSAIDs) are unclear. MODEL: Here we present a model that shows that the long-term vascular effects of NSAIDs can be the consequences of their antiproliferative cellular mechanism that secondarily and protractedly leads to vascular calcification. METHOD: Enhanced Entity Relationship Modelling with structured data mining. MODEL ANALYSIS: The intra-mitochondrial uncoupling of oxidative phosphorylation induced by NSAIDs increases biochemically, through a reduced activity of ATP-dependent ionic pumps, the intra-cellular calcium x phosphate product with a consecutively increased formation of calcium phosphate compounds. The latter cause, by chemical replication mechanisms in arterial media layers, a mineralization with a sclerotic effect. CONCLUSION: Vascular NSAID long-term effects are a consequence of the inhibitory effect they have on oxidative phosphorylation. The induced calcifying vascular processes show a direct analogy to the cardiovascular complications of chronic renal diseases and an avalanche characteristic of early arteriosclerotic development. In the long term, that implies an increased arteriosclerotic risk that increases with the age, probably also with diabetes. Since the consequential cellular processes run under exogenously influenceable conditions of chemical balance, even late phases of such sclerotic-degenerative processes appear to be reversible and thus accessible to therapeutic interventions. Based on these model findings, at least the induction and the early phase of an arteriosclerosis do not correlate with the lipid profile.

Introduction

The uncovering of clinically relevant increased risks of myocardial infarctions (MI) and strokes caused by non-steroidal anti-inflammatory agents (NSAID) of the type of selective cyclooxygenase-2 (COX-2) inhibitors, i.a. Rofecoxib, was only made in recent times on the basis of clinical long-term studies. There was moreover a suspicion that such undesirable vascular effects, even though of a different intensity, might refer to all NSAIDs [1]. That was confirmed by further examinations according to which an increased mortality risk exists with all dosages of COX-2 inhibitors for patients with an already existing cardiovascular disease, which however applies also to higher dosages of non-selective NSAIDs [2]. That did not seem to be surprising because increased rates of MI and stroke are already known for numerous non-selective NSAIDs, in which connection Diclofenac obviously played a prominent role [3][4]. But also for other NSAIDs that are clearly classified as safe, such as e.g. acetylsalicylic acid (Aspirin), there are still some question marks in this connection. In the case of Aspirin, this regards in particular its cerebro-vascular effects. Studies on Aspirin state that it considerably increases the risk of a first stroke in old persons without vascular defects [5] and that, in major observation studies, it is connected with a consistently higher stroke risk [6]. Others conclude an increased stroke risk of Aspirin in older patients [7], see an increase in the risk of haemorrhagic strokes [8], an increase in the stroke frequency compared with placebo [9], no positive effect on arteriosclerotic progression [10], as well as no effect on the frequency of attacks of angina pectoris [11]. In a clinical context, it is also essential that several studies moreover described increased risks or rates of hypertension for all NSAIDs examined there, depending on the dosage for women and for men [12][13][14].

All effects that clinically go along with an MI or stroke point to basic mechanisms that, in their final stage, lead to a development of obstructive vascular processes. Increased vascular calcifications belong to the biochemical processes that favour or cause such kinds of dystrophic-degenerative processes. In biological systems, pathological calcifications are for the most part chemically composed of calcium phosphates as well as complex compounds derived therefrom, first of all hydroxyapatite, and vascular calcifications after deposition of calcium crystals in the smooth vascular musculature are involved into the pathogenesis of arteriosclerosis. Therefore, in relation to the antiproliferative degenerative effects of the NSAIDs, the focus shall be on these biochemical relations and their clinical relevance here.

A Model of Pathophysiologic Consequences of the Uncoupling of the Oxidative Phosphorylation by NSAIDs

Premises: The Antiproliferative Effects of NSAIDs

Regeneration-inhibiting effects of the NSAIDs have already been known from their clinically evident delay of wound healing. In that connection, they do not only reduce cell proliferation, but may also trigger apoptosis. As to the external basic pattern, the overall spectrum of undesirable effects of NSAIDs corresponds to a large extent to that of numerous chemotherapeutic cytostatics. Vice-versa, there shall be mentioned in addition the reports on positive therapeutic effects of some NSAIDs e.g. in case of tumours of the colon.

A biochemical basis of the antiproliferative NSAID effects lies in their influence on mitochondrial oxidative phosphorylation. The pharmacological inhibitory effect of NSAIDs on it has been proven. NSAIDs, such as i.a. Aspirin, Diclofenac, cannot only cause an uncoupling of the oxidative phosphorylation in the mitochondria [15][16][17][18][19], the mitochondrial dysfunction is further increased by the addition of calcium ions (Ca²⁺)[20], obviously also after oral application [21]. Since salicylate toxicity is increased by the increase in intra-cellular Ca²⁺, that aspect was several times associated with the triggering of a Reye's syndrome by Aspirin [22]. Also a worsening of post-ischemic cardiac dysfunction by aspirin does rather seem to be attributable to its uncoupling effect on oxidative phosphorylation, and thus to be independent from a COX inhibition [23], in particular since it was proven that Aspirin and salicylate uncouple also a respiration in the myocardial tissue (in stadium 3) [24]. In the same manner, however, also selective COX-2 inhibitors uncouple the mitochondria of intact cells [25]. Because the mitochondrial Ca²⁺ overloading moreover may lead to cell degeneration as well as to apoptosis [26][27][28][29][30], that appears, in the context of the Ca²⁺-sensitive NSAID uncoupling effects, to be also relevant with regard to undesirable vascular effects.

Method : eERM

A model of the consequential processes focusing on "metastatic calcification on the basis of an inhibition of oxidative phosphorylation" was prepared. It was the overall aim of the model to clarify functional causality (process logic) and contextual clinical relevance. That was done by modified enhanced Entity Relationship Modelling (eERM) and structured Data Mining of relevant literature (i.a. Medline) as well as application of a syntax for interactive data configuration newly developed for that purpose (BMA/3.1). The model preparation itself was only based on the analysis of experimental studies. Metastudies were excluded. Certain cellular parallel processes that, after a preceding individual analysis, did not necessarily need to be included as a logical support of the problem of the model were not implemented. This applies for example to the Na-K ATPase or ATP-dependent potassium channel (KATP), also to a large extent to apoptosis the role of which is only outlined in the model. That, however shall not exclude its secondary influence on the basic process of the problem.

Arrangement of the Basic Processes of the Model

In Figure 1, the overall processes of the problem are represented in a synoptic-descriptive manner and imply a topological and biochemical sequence. In summary, an exogenously induced reduction of the mitochondrial oxidative phosphorylation leads to a reduced synthesis of adenosine triphosphate (ATP). That in turn implies i.a. the induction of apoptosis [(25)][(26) through the release of cytochrome C [30] with a triggering of the Caspase cascade. Functionally, that leads to a reduced activity of all ion pumps that receive their main energy from the ATP hydrolysis. That regards the Ca-ATPases responsible for the maintenance of low intra-cellular calcium ions (Ca²⁺), but also i.a. the Na/K-ATPase. Of relevance

to the process for the intra-cellular Ca^{2+} store are the membrane-bound plasma membrane Ca^{2+} -transporting ATPase (PMCA) and the sarco(endo)plasmic reticulum Ca^{2+} ATPases (SERCA) [31].

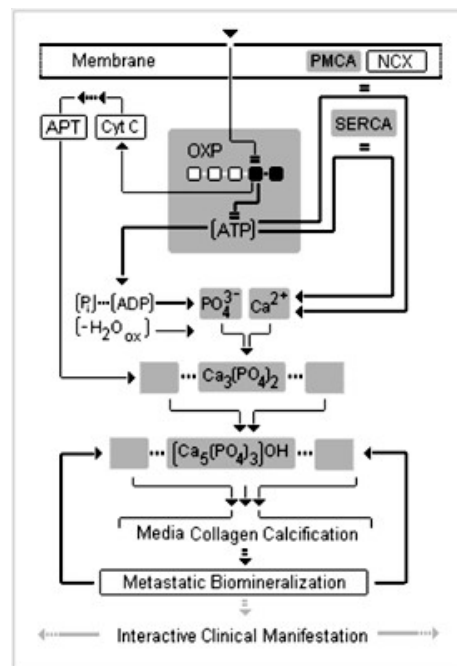

Figure 1. Descriptive synoptic model on consequences of a NSAIDs inhibition of the mitochondrial oxidative phosphorylation of a vascular cell. This phase forms the induction of a triggering of cell-degenerating processes. The reduction of the ATP biosynthesis initializes a pathological intra-cellular calcium x phosphate product ($[\text{PO}_4^{3-}][\text{Ca}^{2+}]$) caused by an accumulation of phosphates on the one hand and Ca^{2+} on the other hand by a reduction of the ATP-dependent calcium ion pumps (PMCA, SERCA). That way, there takes place a transformation into calcium phosphates ($\text{Ca}_3(\text{PO}_4)_2$) with a secondarily increased formation and crystalline deposition of hydroxyapatites ($\text{Ca}_5(\text{PO}_4)_3\text{OH}$). The hydroxyapatite crystals serve as replicative matrixes for further hydroxyapatite complexes that cause, by metastatic calcification, a collagen-associated mineralization of the arterial media. Abbreviations: APT: Apoptotic proteasom, CytC: Cytochrom C, OXP: Mitochondrial oxidative phosphorylation, PMCA: Plasma Membrane Ca^{2+} -transporting ATPase, SERCA: sarco(endo)plasmic reticulum Ca^{2+} -ATPases, NCX: Sodium-Calcium-Exchanger, H_2O_{ox} : OXP oxidation water ; $-->$ Activation $-II$: Blockade/Inhibition.

Moreover, but only indirectly as to ATP energy, also the electrogenic sodium-calcium exchanger (NCX). As a consequence of the disorder of the ATP synthesis, there does not only occur a reduction of the concentration of intra-cellular ATP, but simultaneously an excess of the ATP precursors not used for phosphorylation, and therefore an increase in concentration of phosphate (Pi), adenosine monophosphate (AMP) and adenosine diphosphate (ADP). The Ca^{2+} accumulate cytosolically and intra-mitochondrially due to the calcium pump defects. Therefrom, an increased amount of Ca^{2+} is available to the increasingly unused phosphates as reaction partner. According to the increased intra-cellular calcium x phosphate product (CaxP), there are increasingly formed, as primary reaction products, calcium phosphates ($\text{Ca}_3(\text{PO}_4)_2$). That part of the process can be regarded as transformation phase or phase of nucleation. As a consequence of exceeding the saturation conditions, the calcium phosphates in part deposit in a crystalline form. In that connection, the saturation conditions are favoured because the inhibition of the oxidative phosphorylation leads also to a cellular decrease of oxidation water (H_2O_{ox}). That again leads, in a further step, to an increased crystalline complex formation of the calcium phosphates into ($\text{Ca}_5(\text{PO}_4)_3\text{OH}$). The deposited crystalline hydroxyapatites (HAP) serve as replicative matrixes for an apposition for the production of further HAP crystals (chemical self assembly).

Through cell disruption or also exocytosis, a further export and crystalline tissue deposit of HAP may occur, obviously first by deposit of HAP into the collagen of the media layer, with a presumed active involvement of the proteins osteonectin and osteopontin, the externally deposited HAP again serving as

replicative templates for the production of further HAP crystals. These deposits contribute to a stiffening of the collagen fibres. This part of the process can be designated as a phase of metastatic biomineralization and finally is a process that has its starting point in the mitochondrial dysfunction. Through that progressive mechanism, the degenerative process in the collagen of vascular myofibrils extends further and the exported HAP induces a further vascular calcification. Moreover, the HAP may secondarily, by physical stimulation, also generate inflammatory effects.

Thus, the total effect develops forcibly as a biochemical-cellular consequence of the auto-multiplying avalanche comprising the phases of induction, transformation, metastatic biomineralization and then leads to interactive clinical manifestations. Since the phases of transformation and biomineralization follow conditions of chemical balance the reaction conditions of which can be influenced by exogenous intervention, they are reversible in principle.

Although all of the known arteriosclerotic risk factors show an increase in apoptosis, which indicates that their effect might be based on a reduction of the regeneration potential, this model outlines the apoptosis aspect only in connection with the increased release of cytochrome C because it appears not to be absolutely necessary for the course of and the basic statements on the mechanism of metastatic calcification processes.

Discussion

The metastatic calcification is caused by the initially excessive level of intra-cellular calcium x phosphate product (CaxP) from which then results, as a process that is ATP energy-independent to a large extent, a production of calcium phosphate for the formation of chemically replicative matrixes for HAP [32]. The replicative HAP process can be considered in principle as a kind of chemical self-assembly as known in materials science from the formation of molecular crystals (also of colloids, phase separated polymers etc).

That way, the NSAIDs, through their inhibitory effect on mitochondrial oxidative phosphorylation, initialize in summary only the increased formation of biochemical products with a degenerative or apoptotic potential. Only the disseminated HAP on its part than induces, in a replicative manner, further vascular calcification, possibly also inflammatory effects. Thus, such consequential effects develop from every exogenous intervention that has an antiproliferative effect and can be explained unconstrainedly without considering further chemical mediators or, with regard to the NSAIDs, a COX inhibition.

The biological age seems to be process-relevant as a negatively predisposing parameter for the calcification because it correlates in principle with a reduced regenerative capacity and therefore points implicitly to an already reduced ATP generation from the oxidative phosphorylation. That is also supported, in conformity with the model, by findings according to which the activity of PMCA decreases with the age, too [33]. In addition, the NSAIDs possibly may also interact directly with the PMCA [34] after which they would functionally act as cellular "calcium efflux inhibitor". In the context of the initial intra-cellular Ca²⁺ condition as well as the already existing age-dependent reduction of regenerative cell capacity, that would explain that the vascular calcification effects caused by NSAIDs are more grave in older patients because they are superimposed on an already existing relative regenerative insufficiency. In formal analogy with the model, similar dystrophic-calcifying long-term effects should also be detectable in antiproliferative cytostatics. A respective connection, referring to the NSAID Celecoxib through its influence on the SERCA, was already assumed [35]. Possibly, the NSAIDs may altogether suggest themselves on that basis as a more gentle approach to the treatment of some neoplasias.

The calcium avalanche of calcifying vascular processes induced by NSAID on a cellular level shows direct analogies to the cardiovascular complications of chronic renal diseases, in particular with haemodialysis. It does quasi deliver an extra-cellular time-lapse version of the protracted cell model. The strong link between chronic renal diseases and metastatic vascular calcification, in particular in case of haemodialysis, is known, just like the fact that those patients often show hyperphosphataemia and increased CaxP. Especially late stages of chronic renal diseases show strongly progressive and metastatic vascular calcification with an increased cardiovascular mortality [36]. The progression of coronary calcification in haemodialysis patients correlated with the prevalence of MI, length of the dialysis application as well as calcium and phosphate serum concentrations, but not with cholesterol and lipoproteins [37]. Since hyperphosphataemia and/or a high CaxP form a predisposition for

metastatic calcification, the mortality was also connected with increased CaxP [38]. That way the therapy of hyperphosphataemia and high CaxP was also given a central role for reducing the risk of cardiovascular mortality [39][40]. In haemodialysis patients, the baseline of a calcium score of the coronaries is moreover a significant risk predictor [41]. With a calcification initialised in the coronaries, an inflammation probably may modify the process, while the lipid profiles appeared to influence neither their initiation nor their progression [42]. Interesting enough, in the therapy of hyperphosphataemia, the application of phosphate binders containing calcium resulted in a stronger progression of the coronary calcification than the application of calcium-free phosphate binders [43][44]. In that therapy route, there appeared moreover also indications that were assessed as anti-atherogenic by the authors [45]. But also in persons with healthy kidneys, there was found a relation between calcium supplementation and increased rates of MI and stroke [46].

The context between negative NSAID effects and intra-cellular CaxP and negative extra-cellular CaxP effects in renal diseases with regard to metastatic vascular calcification suggests that the depositing of complex calcium crystals like HAP is responsible for an induction of early arteriosclerotic phases. Obviously, the initialisation first is prepared by a biomineralization by increased deposition of HAP on the collagen that takes place in the media layer. On the whole, such kind of induced vascular calcification seems to be a process that has numerous similarities to bone mineralization. That is further supported by the finding that, in late renal diseases, there is found a stronger calcification in the coronary media than in the intima; which applies also to patients without a renal disease [47][48]. Also in uraemic patients, the media thickness and calcification of the coronary arteries was significantly more pronounced [49].

Presumably, the initial stage of such a process occurs sub-clinically as a vector from the vascular media to the intima layer, wherein the mineralizing destruction of the structure of elastic proteins in smooth muscular cells of the vessel triggers the “hardening of the arteries” first. This aspect offers also an approach to an explanation of the formation of hypertension by NSAIDs [12][13][14] as an early effect. Before the start of a haemodialysis treatment, media calcifications were also found in younger patients without traditional arteriosclerosis risk factors, while an intima calcification was rather found in older patients with a history of arteriosclerosis [48]. In the same manner, also an increase in the intima-media thickness of the carotid artery was rather found in persons of a higher age and with a longer duration of the disease [50], in diabetics type 2 [51], and it was also significantly increased in patients with a systemic sclerosis compared with healthy persons examined [52].

The calcifying media sclerosis frequently found in diabetics shall only be mentioned here in so far as it appears to be of clinical relevance in the context of NSAIDs. Presumably, it is based on the same consequences of this deficit-energy model process: An intact insulin secretion depends strongly on a sufficient function of the ATP-dependent calcium channels (PMCA, SERCA), while the ATP-dependent potassium-ion channel (KATP) must also be included here. Since NSAIDs inhibit that axis of mitochondrial ATP synthesis that is of central significance to the insulin secretion, the application of NSAIDs in diabetics may involve an increased degenerative vascular risk on that basis.

The final phase of a chemical self assembly of HAP appears important for the progression and extent of the clinical outcome. This kind of spontaneous formation of supramolecular structures in the body is presumably an own and separate physico-chemical process which includes calcium ions and organic ligands. Some basic processes of the crystalline nucleation and technical in-vitro assessments on the mechanism of HAP self assembly in simulated body fluid have been described [53][54][55]. Studies were also made on composites with collagen, which complied biologically with extracellular matrix fibers [56] or bone structures [57][58]. An important aspect for a biological apatite nucleation and its expansion, appears a contribution of specific extracellular matrix proteins which bind calcium ions [59]. On the other hand the process of nucleation can also be inhibited by the protein osteonectin [60]. Technically of importance for the HAP self assembly are the qualitative composition of phosphates [61], the conditions of chemical saturation [62] and the pH. Since the mechanics of this process is significantly different to usual cellular biochemical processes it is in large part uncoupled from a direct biological feed-back. At least some of the early phases of the cellular calcification appear still below the radar screen of secondary hormonal control mechanisms. This latency of the early processes, their more pronounced chemical-technical nature, and a lack of specific biomarkers, complicate a clinical approach. Since the metastatic phase can be in sum considered a chemical-stoichiometrical process, its progression depends from the acute systemic reaction conditions of the biological system. However based on this it also offers a therapeutic chance of an exogenous chemical intervention.

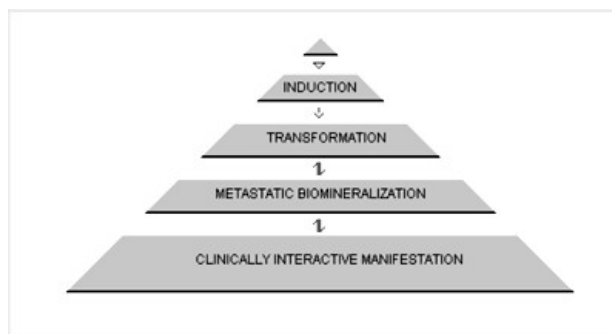

The overall sequence of induction - transformation - metastatic biomineralization shows the characteristic of an avalanche. (Fig 2). The myofibrillar calcifications in the transformation phase or nucleation

Figure 2. In particular the replication mechanisms in the post-transformation phases accelerate the occurrence of pathologic effects with a manifestation of interactive clinical consequences.

phase first cause a long-term sub-clinically progressive media thickening and media stiffening, and thus an early phase of "local hypertension". Within the framework of metastatic biomineralization, there must also be expected a more frequent occurrence of systemic effects and also an increased brittleness and intima immigration, from which then results the more intra-vascular-directed process of plaque formation and its further clinical consequences.

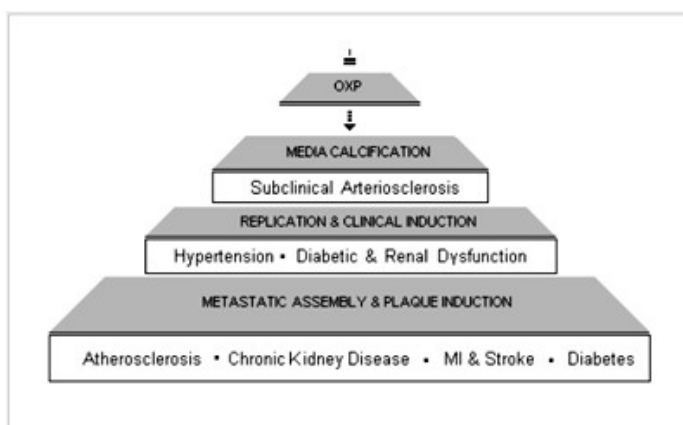

Figure 3: Scheme of a sequence of pathophysiological events, which may correlate with the different phases of cellular calcification. This also indicates a strong interrelation of different clinical-pathological entities to the same basic process (OXP: mitochondrial oxidative phosphorylation)

Therefore, the phase of metastatic biomineralization implies, apart from the extension, also an acceleration of the processes. But since the transformation phase, just like the biomineralization are subject to conditions of chemical balance the direction of which can be exogenously influenced, these processes are reversible and therefore can also be therapeutically influenced at different levels of intervention.

Conclusion

The defect in oxidative phosphorylation induced by NSAIDs does biochemically cause an increased formation of compounds with a calcifying degenerative effect that are disseminated into other tissues. The increased vascular calcification is caused by the formation, implemented in the mechanism of action of NSAIDs, of an increased intra-cellular CaxP product from which replicative matrixes for hydroxyapatite are forming. The at first only cellular, latently accumulating Ca/P imbalance than is spreading in several phases through an increased export of hydroxyapatite. Analogously to the protracted NSAID effects in the cellular/sub-cellular area, the metastatic calcification effects in chronic renal diseases and dialysis with an increased CaxP product constitute a clinical model in which these effects, with the same clinical consequences, occur in an accelerated manner. The model indicates an early phase of arteriosclerosis development with a vector pointing from the media to the intima and an

indication of inducement of early hypertension by NSAIDs. Since the calcification phases are subject to influenceable conditions of chemical balance, these processes are reversible and therefore therapeutically influenceable.

References

[1] Kearney PM, Baigent C, Godwin J, Halls H, Emberson JR, Patrono C, Do selective cyclooxygenase-2 inhibitors and traditional non-steroidal anti-inflammatory drugs increase the risk of atherothrombosis? Meta-analysis of randomised trials. *BMJ* 2006 3;332(7553):1302-8

[2] Gislason GH, Jacobsen S, Rasmussen JN, Rasmussen S, Buch P, Friberg J, Schramm TK, Abildstrom SZ, Kober L, Madsen M, Torp-Pedersen C, Risk of death or reinfarction associated with the use of selective cyclooxygenase-2 inhibitors and nonselective nonsteroidal antiinflammatory drugs after acute myocardial infarction. *Circulation* 2006 113(25):2906-13

[3] Schneeweiss S, Solomon DH, Wang PS, Rassen J, Brookhart MA, Simultaneous assessment of short-term gastrointestinal benefits and cardiovascular risks of selective cyclooxygenase 2 inhibitors and nonselective nonsteroidal antiinflammatory drugs: an instrumental variable analysis. *Arthritis Rheum.* 2006 Nov;54(11):3390-8

[4] McGettigan P, Henry D. Cardiovascular risk and inhibition of cyclooxygenase: a systematic review of the observational studies of selective and nonselective inhibitors of cyclooxygenase 2. *JAMA.* 2006 Oct 4; 296(13):1633-44

[5] Vokó Z, Koudstaal PJ, Bots ML, Hofman A, Breteler MM, Aspirin use and risk of stroke in the elderly: the Rotterdam Study. *Neuroepidemiology.* 2001 Feb;20(1):40-4

[6] Hart RG, Halperin JL, McBride R, Benavente O, Man-Son-Hing M, Kronmal RA. Aspirin for the primary prevention of stroke and other major vascular events: meta-analysis and hypotheses. *Arch Neurol.* 2000 Mar;57(3):326-32

[7] Kronmal RA, Hart RG, Manolio TA, Talbert RL, Beauchamp NJ, Newman A Aspirin use and incident stroke in the cardiovascular health study. CHS Collaborative Research Group. *Stroke.* 1998 May;29(5):887-94

[8] He J, Whelton PK, Vu B, Klag MJ Aspirin and risk of hemorrhagic stroke: a meta-analysis of randomized controlled trials *JAMA.* 1998 Dec 9;280(22):1930-35

[9] Ridker PM, Manson JE, Gaziano JM, Buring JE, Hennekens CH. Low-dose aspirin therapy for chronic stable angina. A randomized, placebo-controlled clinical trial. *Ann. Intern. Med.* 1991, 15;114(10):835-39

[10] Ridker PM, Manson JE, Buring JE, Goldhaber SZ, Hennekens CH. The effect of chronic platelet inhibition with low-dose aspirin on atherosclerotic progression and acute thrombosis: clinical evidence from the Physicians' Health Study, *Am Heart J.* 1991;122(6):588-92

[11] Manson JE, Grobbee DE, Stampfer MJ, Taylor JO, Goldhaber SZ, Gaziano JM, Ridker PM, Buring JE, Hennekens CH., Aspirin in the primary prevention of angina pectoris in a randomized trial of United States physicians. *Am J Med.* 1990 ; 89(6):772-6

[12] Forman JP, Rimm EB, Curhan GC, Frequency of analgesic use and risk of hypertension among men. *Arch Intern Med.* 2007 Feb 26;167(4):394-9

[13] Forman JP, Stampfer MJ, Curhan GC. Non-narcotic analgesic dose and risk of incident hypertension in US women. *Hypertension.* 2005 Sep;46(3):500-7

[14] Dedier J, Stampfer MJ, Hankinson SE, Willett WC, Speizer FE, Curhan GC Nonnarcotic analgesic use and the risk of hypertension in US women.. *Hypertension.* 2002 Nov;40(5):604-8; discussion 601-3

- [15] Moreno-Sanchez R, Bravo C, Vasquez C, Ayala G, Silveira LH, Martinez-Lavin M, Inhibition and uncoupling of oxidative phosphorylation by nonsteroidal anti-inflammatory drugs: study in mitochondria, submitochondrial particles, cells, and whole heart. *Biochem Pharmacol.* 1999;57(7):743-52
- [16] Petrescu I, Tarba C, .Uncoupling effects of diclofenac and aspirin in the perfused liver and isolated hepatic mitochondria of rat. *Biochim Biophys Acta.* 1997 1318(3):385-94
- [17] Mingatto FE, Santos AC, Uyemura SA, Jordani MC, Curti C. In vitro interaction of nonsteroidal anti-inflammatory drugs on oxidative phosphorylation of rat kidney mitochondria: respiration and ATP synthesis. *Arch Biochem Biophys.* 1996 Oct 15;334(2):303-8
- [18] Salgueiro-Pagadigorria CL, Kelmer-Bracht AM, Bracht A, Ishii-Iwamoto EL Naproxen affects Ca(2+) fluxes in mitochondria, microsomes and plasma membrane vesicles. *Chem Biol Interact.* 2004 Jan 15;147(1):49-63
- [19] Wang JL, Lin KL, Chen JS, Lu YC, Jiann BP, Chang HT, Hsu SS, Chen WC, Huang JK, Ho CM, Jan CR, , Effect of celecoxib on Ca2+ movement and cell proliferation in human osteoblasts. *Biochem Pharmacol.* 2004 15;67(6):1123-30
- [20] Martens, ME, Lee CP, Reye's syndrome: salicylates and mitochondrial functions. *Biochem Pharmacol.* 1984 Sep 15;33(18):2869-76
- [21] Tomoda, T, Takeda Kurashige T, Enzan H, Miyhara M Acetylsalicylate-induced mitochondrial dysfunction and its potentiation by Ca2+. *Liver* 1994;14(2):103-8
- [22] Trost LC, Lemasters JJ, Role of the mitochondrial permeability transition in salicylate toxicity to cultured rat hepatocytes: implications for the pathogenesis of Reye's syndrome. *Toxicol Appl Pharmacol* 1997 ;147(2):431-41
- [23] Heindl B, Becker BF Aspirin, but not the more selective cyclooxygenase (COX)-2 inhibitors meloxicam and SC 58125, aggravates postischemic cardiac dysfunction, independent of COX function. *Naunyn Schmiedebergs Arch Pharmacol* 2001 Feb;363(2):233-40
- [24] Nulton-Persson, AC, Szweda LI, Sadek HA Inhibition of cardiac mitochondrial respiration by salicylic acid and acetylsalicylate. *J. Cardiovasc. Pharmacol* 2004;44(5):591-5
- [25] Krause MM, Brand MD, Krauss S, Meisel C, Vergin H, Burmester GR, Buttgerit F, Nonsteroidal antiinflammatory drugs and a selective cyclooxygenase 2 inhibitor uncouple mitochondria in intact cells, *Arthritis Rheum* 2003;48(5):1438-44
- [26] Duchen MR, Mitochondria and calcium: from cell signalling to cell death, *J Physiol* 2000; 529 Pt 1:57-68
- [27] Oh KW, Qian T, Brenner DA, Lemasters JJ. Salicylate enhances necrosis and apoptosis mediated by the mitochondrial permeability transition. *Toxicol Sci.* 2003 May;73(1):44-52
- [28] Dikshit P, Chatterjee M, Goswami A, Mishra A, Jana NR, Aspirin induces apoptosis through the inhibition of proteasome function, *J Biol Chem.* 2006 29;281(39):29228-35
- [29] Tanaka K, Tomisato W, Hoshino T, Ishihara T, Namba T, Aburaya M, Katsu T, Suzuki K, Tsutsumi S, Mizushima J Involvement of intracellular Ca2+ levels in nonsteroidal anti-inflammatory drug-induced apoptosis. *Biol Chem.* 2005 Sep 2;280(35):31059-67
- [30] Pique M, Barragan M, Dalmau M, Bellosillo B, Pons G, Gil J, Aspirin induces apoptosis through mitochondrial cytochrome c release *FEBS Letters* 2000 1;480(2-3):193-6
- [31] Shull GE, Okunade G, Liu LH, Kozel P, Periasamy M, Lorenz JN, Prasad V, Physiological functions of plasma membrane and intracellular Ca2+ pumps revealed by analysis of null mutants. *Ann N Y Acad Sci.* 2003 Apr;986:453-60

- [32] Kim KM, Cell injury and calcification of rat aorta in vitro, *Scan Electron Microsc.* 1984;(Pt 4):1809-18
- [33] Hanahisa Y, Yamaguchi M, Decrease in Ca²⁺-ATPase activity in the brain plasma membrane of rats with increasing age: involvement of brain calcium accumulation. *Int J Mol Med.* 2001 Apr;7(4):407-11
- [34] Omer B, Oner P, Baysal K, Oz H, Effect of acetylsalicylic acid on liver plasma membrane Ca²⁺-ATPase activity, *Pol J Pharmacol Pharm* 1990; 42(5):441-6
- [35] Johnson AJ, Hsu AL, Lin HP, Song X, Chen CS. The cyclo-oxygenase-2 inhibitor celecoxib perturbs intracellular calcium by inhibiting endoplasmic reticulum Ca²⁺-ATPases: a plausible link with its anti-tumour effect and cardiovascular risks. *Biochem J.* 2002 5;366(Pt 3):831-7
- [36] Sigrist MK, Taal MW, Bungay P, McIntyre CW. Progressive vascular calcification over 2 years is associated with arterial stiffening and increased mortality in patients with stages 4 and 5 chronic kidney disease. *Clin J Am Soc Nephrol.* 2007 Nov; 2(6):1241-8
- [37] Raggi P, Boulay A, Chasan-Taber S, Amin N, Dillon M, Burke SK, Chertow GM. Cardiac calcification in adult hemodialysis patients. A link between end-stage renal disease and cardiovascular disease? *J Am Coll Cardiol.* 2002 Feb 20;39(4):695-701
- [38] Block GA, Hulbert-Shearon TE, Levin NW, Port FK. Association of serum phosphorus and calcium x phosphate product with mortality risk in chronic hemodialysis patients: a national study. *Am J Kidney Dis.* 1998 Apr;31(4):607-17
- [39] Cozzolino M, Brancaccio D. Optimising the treatment of hyperphosphatemia and vascular calcification in chronic kidney disease. *Expert Opin Emerg Drugs.* 2007 Sep;12(3):341-3
- [40] Bellinghieri G, Santoro D, Savica V. Emerging drugs for hyperphosphatemia. *Expert Opin Emerg Drugs.* 2007 Sep;12(3):355-65
- [41] Block GA, Raggi P, Bellasi A, Kooienga L, Spiegel DM. Mortality effect of coronary calcification and phosphate binder choice in incident hemodialysis patients. *Kidney Int.* 2007 Mar;71(5):438-41
- [42] Patsalas S, Eleftheriadis T, Spaia S, Theodoroglou H, Antoniadis G, Liakopoulos V, Passadakis P, Vayonas G, Vargemezis V. Thirty-month follow-up of coronary artery calcification in hemodialysis patients: different roles for inflammation and abnormal calcium-phosphorous metabolism? *Ren Fail.* 2007;29(5):623-9
- [43] Block GA, Spiegel DM, Ehrlich J, Mehta R, Lindbergh J, Dreisbach A, Raggi P. Effects of sevelamer and calcium on coronary artery calcification in patients new to hemodialysis. *Kidney Int.* 2005 Oct;68(4):1815-24
- [44] Chertow GM, Raggi P, Chasan-Taber S, Bommer J, Holzer H, Burke SK. Determinants of progressive vascular calcification in haemodialysis patients. *Nephrol Dial Transplant.* 2004 Jun;19(6):1489-96
- [45] Ferramosca E, Burke S, Chasan-Taber S, Ratti C, Chertow GM, Raggi P. Potential antiatherogenic and anti-inflammatory properties of sevelamer in maintenance hemodialysis patients. *Am Heart J.* 2005 May;149(5):820-5
- [46] Bolland MJ, Barber PA, Doughty RN, Mason B, Horne A, Ames R, Gamble GD, Grey A, Reid IR M, Vascular events in healthy older women receiving calcium supplementation: randomised controlled trial. *BMJ.* 2008 Feb 2;336(7638):262-6
- [47] Gross ML, Meyer HP, Ziebart H, Rieger P, Wenzel U, Amann K, Berger I, Adamczak M, Schirmacher P, Ritz E, Calcification of coronary intima and media: immunohistochemistry, backscatter imaging, and x-ray analysis in renal and nonrenal patients. *Clin J Am Soc Nephrol.* 2007 Jan; 2 (1):121-34

- [48] London GM, Guérin AP, Marchais SJ, Métivier F, Pannier B, Adda H. Arterial media calcification in end-stage renal disease: impact on all-cause and cardiovascular mortality. *Nephrol Dial Transplant*. 2003 Sep;18(9):1731-40
- [49] Schwarz U, Buzello M, Ritz E, Stein G, Raabe G, Wiest G, Mall G, Amann K Morphology of coronary atherosclerotic lesions in patients with end-stage renal failure, *Nephrol Dial Transplant*. 2000 Feb;15(2):218-23
- [50] Szucs G, Tímár O, Szekanez Z, Dér H, Kerekes G, Szamosi S, Shoenfeld Y, Szegedi G, Soltész P. Endothelial dysfunction precedes atherosclerosis in systemic sclerosis--relevance for prevention of vascular complications. *Rheumatology (Oxford)*. 2007 May;46(5):759-62
- [51] Ifrim S, Vasilescu R . Early detection of atherosclerosis in type 2 diabetic patients by endothelial dysfunction and intima-media thickness, *Rom J Intern Med*. 2004;42(2):343-54
- [52] Bartoli F, Blagojevic J, Bacci M, Fiori G, Tempestini A, Conforti ML, Guiducci S, Miniati I, Di Chicco M, Del Rosso A, Perfetto F, Castellani S, Pignone A, Cerinic MM, Flow-mediated vasodilation and carotid intima-media thickness in systemic sclerosis. *Ann N Y Acad Sci*. 2007 Jun; 1108:283-90,
- [53] Jiang H, Liu XY, Zhang G, Li Y, Kinetics and template nucleation of self-assembled hydroxyapatite nanocrystallites by chondroitin sulfate, *J Biol Chem*. 2005 Dec 23;280(51):42061-6
- [54] Kim HM, Himeno T, Kawashita M, Kokubo T, Nakamura T. The mechanism of biomineralization of bone-like apatite on synthetic hydroxyapatite: an in vitro assessment, *J R Soc Interface*. 2004 Nov 22;1(1):17-22
- [55] Gu YW, Khor KA, Bone-like apatite layer formation on hydroxyapatite prepared by spark plasma sintering (SPS), *Biomaterials*. 2004 Aug; 25(18):4127-34
- [56] Zhang W, Liao SS, Cui FZ, Hierarchical Self-Assembly of Nano-Fibrils in Mineralized Collagen, *Chem Mater* 2003, 15(16), 3221-3226
- [57] Honda Y, Kamakura S, Sasaki K, Suzuki O. Formation of bone-like apatite enhanced by hydrolysis of octacalcium phosphate crystals deposited in collagen matrix, *J Biomed Mater Res B Appl Biomater*, 2007 Feb; 80(2):281-9
- [58] Kikuchi M, Itoh S, Ichinose S, Shinomiyab K, Tanaka J, Self-organization mechanism in a bone-like hydroxyapatite/collagen nanocomposite synthesized in vitro and its biological reaction in vivo, *Biomaterials* 2001 July, 22 (13) 1705-1711
- [59] He GT, Veis A, George A, Nucleation of apatite crystals in vitro by self-assembled dentin matrix protein 1, *Nature Materials* 2003 2,552-558
- [60] Doi Y, Okuda R, Takezawa Y, Shibata S, Moriwaki Y, Wakamatsu N, Shimizu N, Moriyama K, Shimokawa H, Osteonectin inhibiting de novo formation of apatite in the presence of collagen, *Calcif Tissue Int*. 1989 Mar; 44(3):200-8
- [61] Garimella R, Bi X, Anderson HC, Camacho NP, Nature of phosphate substrate as a major determinant of mineral type formed in matrix vesicle-mediated in vitro mineralization: An FTIR imaging study, *Bone* 2006 Jun;38(6):811-7
- [62] Weng J, Liu Q, Wolke JG, Zhang X, de Groot K, Formation and characteristics of the apatite layer on plasma-sprayed hydroxyapatite coatings in simulated body fluid, *Biomaterials* 1997 Aug; 18(15):1027-35